

Upgrade and Extension of the Climate station at DTU Byg



Elsa Andersen
Janne Dragsted
Troels V. Kristensen
Lars Kokholm Andersen

Technical Report

Department of Civil Engineering
2014

DTU Civil Engineering Report SR 14-01 (UK)
July 2014

Table of Contents

1. Preface.....	1
2. Background and objective of the project	2
3. The new Climate station.....	4
4. Results from the new Climate station	11
5. References	14

1. Preface

In the period 2013-2014 the project “Upgrade and Extension of the Climate Station at DTU Byg” is carried out at DTU Byg. The aim of the project is to renew the hardware and the software for data acquisition and monitoring, exchange cables and cable connections in order to avoid interference of electrical noise from the surroundings and exchange worn out equipment. Further, the aim is to make measured data from the climate station easily available for the users.

The project is financed by the Bjarne Saxhof foundation.

2. Background and objective of the project

Detailed measurements of weather data are used to study the weather and develop solar radiation processing models that are needed in order to simulate the energy consumption of buildings, the indoor climate, the thermal performance of solar heating systems and the performance of PV systems. The weather varies from one year to another. Therefore design reference years based on minimum 10 years of measured weather data are used in simulations. In order to work out reliable design reference years, it is needed to know the short term variations in the solar radiation. Hourly values of solar radiation are not always sufficient because of the short time constant of e.g. PV panels. On this background, a solar radiation measurement station was established on the roof of building 119 at DTU Byg. The station was put in operation in 1989 and has been in operation ever since [1], see Figure 1.

The measurements are unique because of the very detailed measurements of the solar radiation, especially the diffuse solar radiation and because of the long measurement period of about 25 years.



Figure 1. Pictures of the solar radiation measurement station before upgrade and renovation. Top left: Measurement equipment. Top middle: Shadow ring. Top right: the old tracker (Eppley). Bottom left: Pyranometer, type CMP 11 from Kipp and Zonen. Bottom middle left: Sunshine pyranometer, type SPN1. Bottom middle right: Weather station, type Vaisala WTX520 from Oyj in Finland. Bottom right: Vaisala mounted 6 meter above the roof of building 119.

The measured weather data from the solar radiation measurement station comprise:

- Global radiation

- Diffuse radiation measured with a shadow ring. The measurements must be corrected afterwards in order to include the part of the diffuse radiation screened of by the shadow ring. The dimensions of the shadow ring are: diameter of 650 mm, width of 58 mm.
- Diffuse radiation measured with a tracker (Eppley) with a disk that screens of the beam radiation from the sun disk. The width of the disk is 5.7°.
- Direct normal beam radiation measured with a pyrheliometer.
- Total solar radiation on 45° tilted south oriented surface
- Total solar radiation on 90° tilted surfaces pointing towards south, east, west and north
- Long wave radiation to the sky
- Ambient temperature
- Relative humidity
- Dew point temperature

The tracker (Eppley) was modified with a step motor and a control system for the step motor that moved the tracker/changed the azimuth angle of the tracker every 2 minutes. The zenith angle was adjusted manually three times a week. The shadow ring from the other diffuse radiation measurement was adjusted at the same time/frequency as the zenith angle of the tracker.

The data logging was running on a very old DOS based computer without internet connection and today it is no longer possible to get service and spare parts for the old computer.

In 2008 a Vaisala weather station was added to the solar radiation measurement station. The Vaisala weather station was positioned 6 meters over the roof and added measurements of rain (rainfall, rain current and peak intensity, duration of a rain event), wind speed and wind direction, atmospheric pressure, ambient temperature and humidity to the test facility.

The solar radiation measurement station was renamed to Climate station.

The measurements are frequently used in research projects and in student projects and it is considered to be in the interest of DTU Byg to keep this unique Climate station in operation.

Much manpower has been used in order to keep the test facility in operation since 1989. The work load included adjustment of the shadow ring and the tracker, maintenance of the tracker, cleaning of the instruments, calibrating the instruments and making sure the data was good and useful and servicing the users by supplying the weather data that was asked for. All in all, the load of maintenance, operation and service of users has been very time consuming.

The objective of this project is to renovate and upgrade the Climate station to the standard of today in order to minimize the work load related to operating the Climate station and providing service to the users.

3. The new Climate station

The new Climate station has got new hardware and new software. The hardware is from National Instruments and comprises a compactRIO control and monitoring system with a number of input/output modules, I/O modules. The compactRIO is a stand-alone computer with internet access. In case of a power failure, the compactRIO will automatically restart when the power is back. The I/O modules are analogue input modules of the types NI9205 and NI9214 that both measure the voltage from the pyranometers and type NI9217 that measures the temperatures from PT100 sensors. Apart from two RS232 channels on the compactRIO, the monitoring system has one RS232 module, type NI9870 with four channels. The RS232 channels allow the readings from the sunshine pyranometer, type SPN1 and the readings from the Vaisala weather station, type WXT520 from Oyj in Finland to be included in the measurement program, see figure 2.

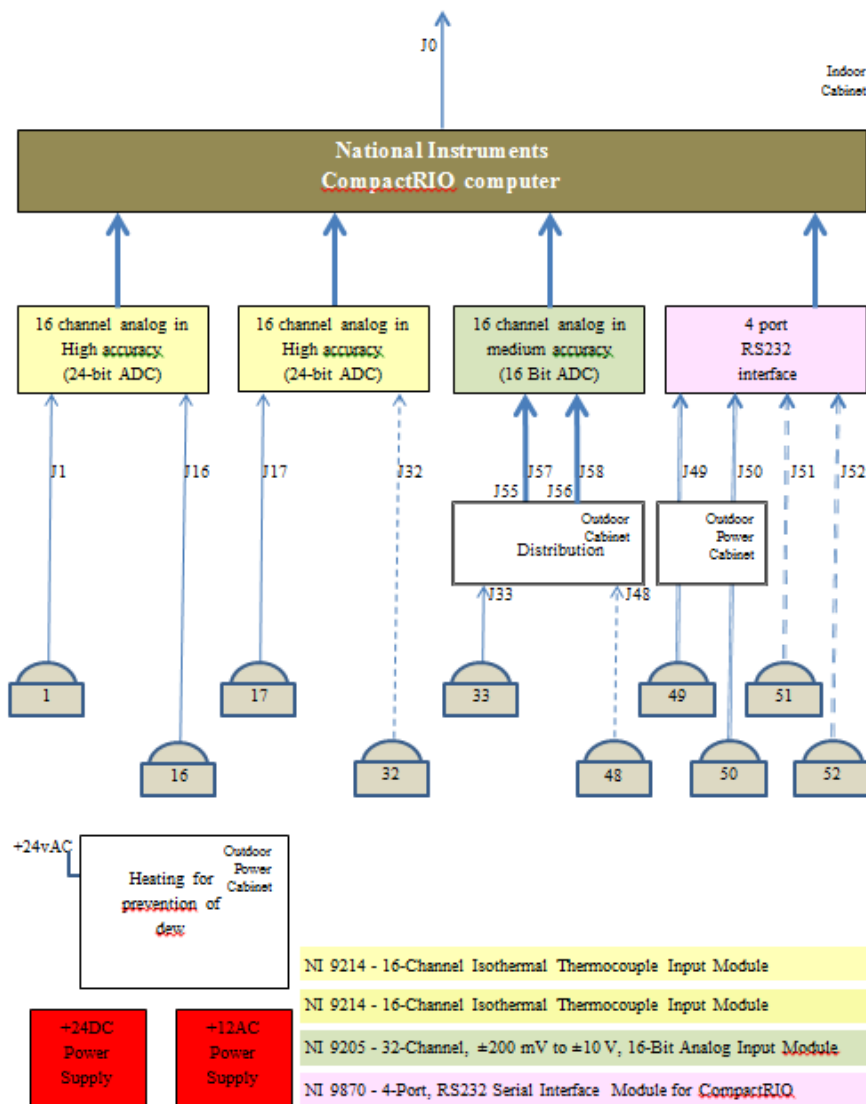

Figure 2. Schematically illustration of the data acquisition and monitoring setup and the cable connections between the instruments and the data monitoring system.

Also, new 230 Volt AC power installation is established at the climate station. This installation supplies the power to the tracker and to small heating loops used to evaporate moisture from the glass domes of the pyranometers, see figure 3 and figure 4.

To eliminate dew, heating elements are mounted around the glass dome:
- heating element made of copper-constantan thermo couple type TT. 2.75 m TT winded as a long spiral. The element emits 10 W of heat at 12 Vac.

The power supply is a dual output 12 Vac transformer and can support a maximum of 40 Heat elements.

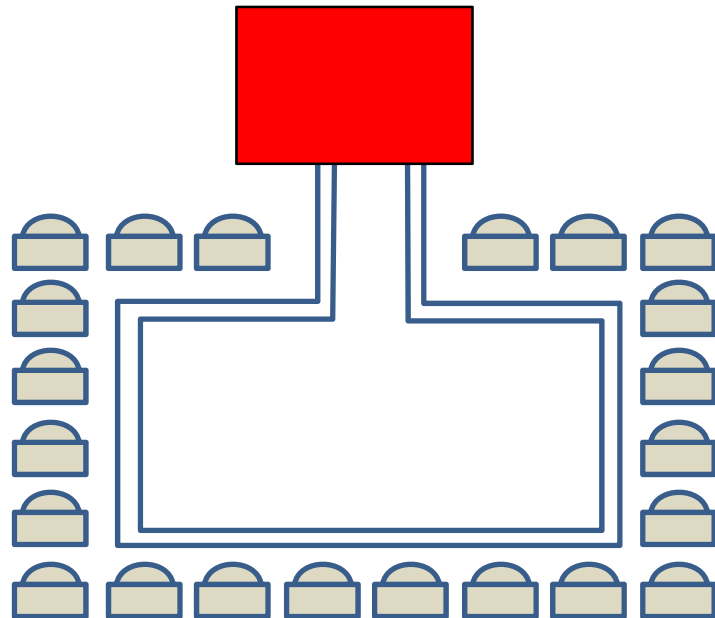

Figure 3. 12 Vac power supply.



Figure 4. Pictures of the heating elements used to evaporate moisture from the glass dome of pyranometers.

In order to eliminate noise from electrical sources in the surroundings of the cables from the instruments to the data logger, the cables are twisted pairs with 80% braid coverage. The data logger is placed in an Electromagnetic Compatibility, EMC cabinet. Another EMC cabinet is placed

outdoor at the platform of the Climate station. All connections are carried out with shielded plugs. In this way electrical noise cannot disturb the measurements, see figure 5.

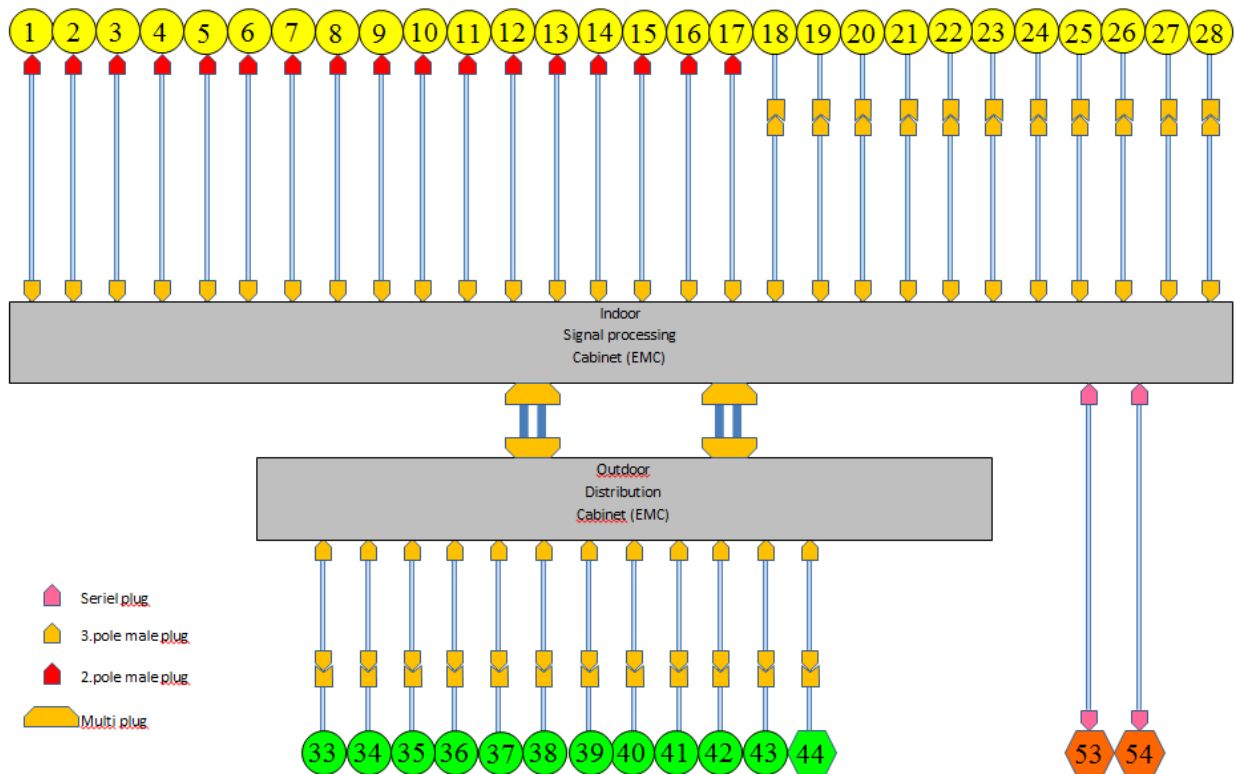

Figure 5. Connector types.

With one NI9205 I/O module and two NI9214 I/O modules, it is possible to measure the response from 48 different solar radiation instruments. The measurement accuracy of NI9205 lays in the range 11 – 55 μV corresponding to an accuracy in the range 1.5 – 10 W/m^2 while the accuracy of NI9214 is about 8 μV corresponding to an accuracy of around 1 W/m^2 .

The old tracker has been replaced by a new tracker from Kipp and Zonen, type SOLYS 2. This tracker has an integrated GPS receiver that allows the tracker to automatically determine its location and the time and operate according to this. Apart from this the tracker has been equipped with a solar sensor from Kipp and Zonen for active tracking. The solar sensor fine tunes the tracking perfectly.

A pyranometer from Kipp and Zonen, type CMP 11 for measuring of the diffuse radiation and a pyrhelimeter, type CHP 1 for measuring of the beam normal radiation are mounted on the tracker, see figure 6.



Figure 6. The SOLYS 2 tracker. On the top mounting plate, the pyranometer that measures the diffuse irradiance can be seen. On the left side of the tracker, the solar sensor and the pyrheliometer that measured the beam normal irradiance can be seen.

Apart from the new measurement equipment, most of the old measurement equipment is renovated and reused. Table 1 shows the measurement equipment in operation at the climate station. Figure 7 shows a top view of the climate station with indication of the location of the different measurement instruments. The colors distinguish between how the instruments are connected to the data logger according to figure 5.

By means of the pyranometers inside the domes numbered 1-16 it is possible to determine diffuse radiation from different parts the sky [2].

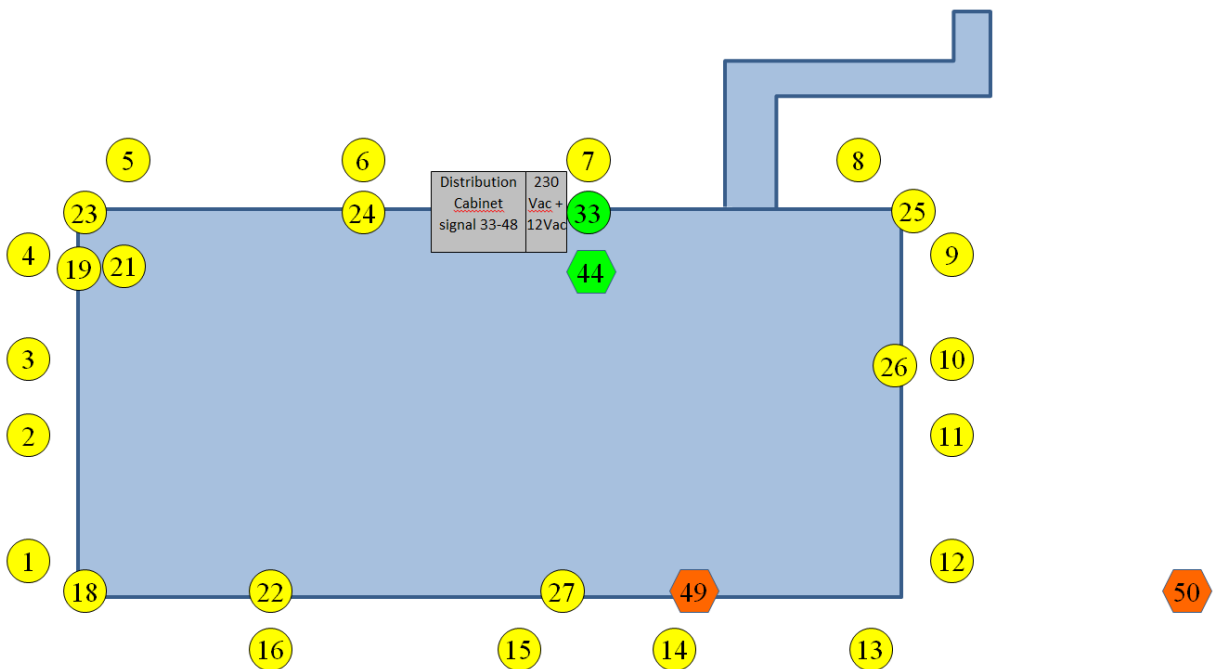

Figure 7. Top view of the Climate station with numbering and placement of the instruments. The numbers correspond to the numbers in table 1.

Table 1. Measurement equipment in use at the new Climate station.

	Parameter	Resolution	Sensor	Accuracy	Correction
1	Pyranometer. 1/16 Dome. Azimuth=174.5°	0.1 W/m ²	CMP11	1.4 %	see fig. 8
2	Pyranometer. 1/8 Dome. Azimuth=174.5°	0.1 W/m ²	CMP11	1.4 %	see fig. 8
3	Pyranometer. 1/16 Dome. Azimuth=129.5°	0.1 W/m ²	CMP11	1.4 %	see fig. 8
4	Pyranometer. 1/8 Dome. Azimuth=129.5°	0.1 W/m ²	CMP11	1.4 %	see fig. 8
5	Pyranometer. 1/16 Dome. Azimuth=84.5°	0.1 W/m ²	CMP11	1.4 %	see fig. 8
6	Pyranometer. 1/8 Dome. Azimuth=84.5°	0.1 W/m ²	CMP11	1.4 %	see fig. 8
7	Pyranometer. 1/16 Dome. Azimuth=41.04°	0.1 W/m ²	CMP11	1.4 %	see fig. 8
8	Pyranometer. 1/8 Dome. Azimuth=41.04°	0.1 W/m ²	CMP11	1.4 %	see fig. 8
9	Pyranometer. 1/16 Dome. Azimuth=-5.42°	0.1 W/m ²	CMP11	1.4 %	see fig. 8
10	Pyranometer. 1/8 Dome. Azimuth=-5.42°	0.1 W/m ²	CMP11	1.4 %	see fig. 8
11	Pyranometer. 1/16 Dome. Azimuth=-49.23°	0.1 W/m ²	CMP11	1.4 %	see fig. 8
12	Pyranometer. 1/8 Dome. Azimuth=-49.23°	0.1 W/m ²	CMP11	1.4 %	see fig. 8
13	Pyranometer. 1/16 Dome. Azimuth=-95.5°	0.1 W/m ²	CMP11	1.4 %	see fig. 8
14	Pyranometer. 1/8 Dome. Azimuth=-95.5°	0.1 W/m ²	CMP11	1.4 %	see fig. 8
15	Pyranometer. 1/16 Dome. Azimuth=-140.5°	0.1 W/m ²	CMP11	1.4 %	see fig. 8
16	Pyranometer. 1/8 Dome. Azimuth=-140.5°	0.1 W/m ²	CMP11	1.4 %	see fig. 8
17	Not in use				
18	Pyranometer for diffuse irradiance on horizontal measured with shadow ring: Radius=650 mm. Width=58 mm.	0.1 W/m ²	CM11	1.4 %	Needed
19	Pyranometer for diffuse irradiance on horizontal measured with tracker.	0.1 W/m ²	CMP11	1.4 %	see fig. 8
20	Not in use				
21	Pyrheliometer for beam normal irradiance. Internal instrument temperature measured with PT100 (see # 53)	0.1 W/m ²	CHP1	1 %	
22	Pyranometer for global irradiance	0.1 W/m ²	CM11	1.4 %	see fig. 8
23	Pyranometer for total solar irradiance on 90° tilt West oriented	0.1 W/m ²	CM5	3 %	
24	Pyranometer for total solar irradiance on 90° tilt North oriented	0.1 W/m ²	CM5	3 %	
25	Pyranometer for total solar irradiance on 90° tilt East oriented. Artificial horizon for rejection of ground reflected irradiance.	0.1 W/m ²	CM5	3 %	
26	Pyranometer for total solar irradiance on 90° tilt South oriented. Artificial horizon for rejection of ground reflected irradiance.	0.1 W/m ²	CM11	1.4 %	see fig. 8
27	Pyranometer for total solar irradiance on 45° tilt South oriented.	0.1 W/m ²	CM5	3 %	see fig. 8
28					
29					

30					
31					
32					
33	Pyrgometer. Atmospheric infrared radiation (PIR).	0.1 W	CGR 3	5 %	
34					
35					
36					
37					
38					
39					
40					
41					
42					
43					
44	Old weather station placed under the solar radiation measurement platform. Temperature / relative humidity	0.01 °C / 0.5 %	Vaisala HMP45 A, PT1000 / DOL 14	0.2 % / ??	
45					
46					
47					
48					
49	Sunshine pyranometer. SPN1, see table 2				
50	Vaisala weather station, see table 3				
51	Not in use				
52	Not in use				
53	Pyrheliometer instrument internal temperature (see #21) Should be used for temperature compensation: Temperature [°C] ; diviation [%]: 50 40 30 20 10 0 -10 -20 ; 0.16 -0.02 -0.07 0.00 0.18 0.19 0.05 -0.48		RTD0 pyrheliometer		
54	Not in use		RTD1		
55	Not in use		RTD2		
56	Indoor Cabinet internal temperature		RTD3		

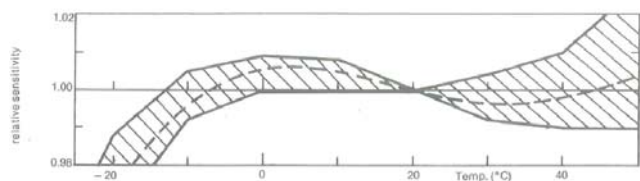
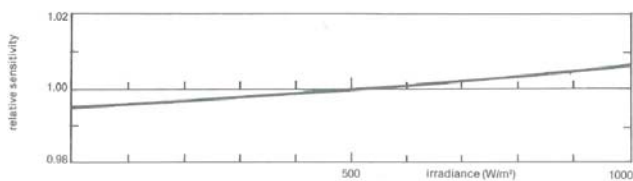

Figure 8. Left: Sensitivity variation with irradiance of Kipp & Zonen pyranometer CM 11 and CMP 11. Right: Relative sensitivity variation with instrument temperature of CM 11 and CMP 11 when placed in a shaded region.

Table 2. Output from the sunshine pyranometer SPN1.

49	Parameter	Resolution	
	Sunshine	0 / 1	0 if solar irradiance $\leq 300 \text{ W/m}^2$ 1 if solar irradiance $> 300 \text{ W/m}^2$
	sun_total [W/m^2]	W/m^2	
	sun_diffuse [W/m^2]	W/m^2	

Table 3. Output from the Vaisala weather station.

50	Parameter	Resolution	
	wind_speed_min [m/s] wind_speed_avg [m/s] wind_speed_max [m/s]	0.1 m/s	The greater of 0.3 m/s or 3% of the measurement range 0...35 m/s 5% for the measurement range of 36...60 m/s
	wind_dir_min [°] wind_dir_avg [°] wind_dir_max [°]	1°	3°
	air_temperature [°C]	0.1 °C	0.3 °C at ambient temperature of 20 °C. For accuracy over temperature range, see figure 9
	relative_humidity [%]	0.1 %RH	3 %RH at 0...90 %RH 5 %RH at 90...100 %RH
	air_pressure [Pa]	10 Pa	0.5 hPa at ambient temperature range 0...36 °C 1 hPa at ambient temperature range -52...60 °C
	rain_fall [mm]	0.01 mm	Cumulative accumulation after latest auto reset. 5 %, weather dependent. Due to the nature of the phenomenon, deviations caused by spatial variations may exist in precipitation readings, especially in short time scale. The accuracy specification does not include possible wind induced error
	rain_duration [s]	10 s	Counting each 10-second increment whenever droplets detected.
	rain_intensity [mm/h]		Running one minute average in 10-second steps
	Hail [hits/cm ²]	0.1 hits/cm ²	Cumulative amount of hits against collecting surface.
	hail_duration [s]	10 s	Counting each 10-second increment whenever hailstone detected.
	hail_intensity [hits/cm ² h]	10 hits/cm ² h	One-minute running average in 10-second steps.

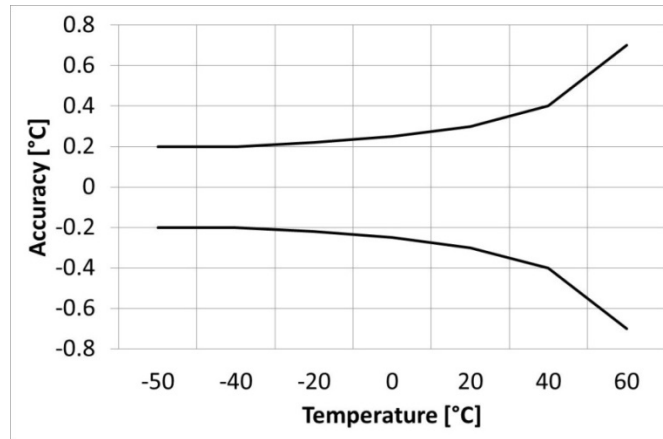

Figure 9. Accuracy over temperature range of the temperature sensor in the Vaisala weather station.

The tracker delivers a number of information about the location and operation of the tracker. When the data are stored in a common result file, it is possible to know exactly if the tracker has been operating as it is supposed to.

4. Results from the new Climate station

The measurement program is made in Labview. The data are averaged of continuous recordings and read to a data file every minute. The data file is uploaded in a common directory at midnight and can be accessed the following day of the recordings.

The result file is described in Table 4. The result file contains measurements from:

- Module 1: NI9214 16-CH isothermal thermocouple input module
- Module 2: NI9214 16-CH isothermal thermocouple input module
- Module 3: NI9205 16-CH differential analog input module,
- Module 4: NI9870 4-Port RS232 serial module
- Module 5: N9217 4-CH RTD analog input module
- Sun tracker and sun sensor.

Table 4. Content of the output file

Ch#	Description	Unit
Time(utc)	UTC time: month, day, year, hour, minute, day Danish winter time: +1 hour Danish summer time: +2hour	[mm-dd-yyy hh:mm:ss]
Measurements from pyranometers and pyrhelimeter (Module 1-3)		
Mod1Ch1	CMP 11: Fractional horizontal diffuse irradiance. 1/16 Dome. Azimuth=174.5°	[W/m ²]
Mod1Ch2	CMP 11: Fractional horizontal diffuse irradiance. 1/8 Dome. Azimuth=174.5°	[W/m ²]
Mod1Ch3	CMP 11: Fractional horizontal diffuse irradiance. 1/16 Dome. Azimuth=129.5°	[W/m ²]
Mod1Ch4	CMP 11: Fractional horizontal diffuse irradiance. 1/8	[W/m ²]

	Dome. Azimuth=129.5°	
Mod1Ch5	CMP 11: Fractional horizontal diffuse irradiance. 1/16 Dome. Azimuth=84.5°	[W/m ²]
Mod1Ch6	CMP 11: Fractional horizontal diffuse irradiance. 1/8 Dome. Azimuth=84.5°	[W/m ²]
Mod1Ch7	CMP 11: Fractional horizontal diffuse irradiance. 1/16 Dome. Azimuth=41.04°	[W/m ²]
Mod1Ch8	CMP 11: Fractional horizontal diffuse irradiance. 1/8 Dome. Azimuth=41.04°	[W/m ²]
Mod1Ch9	CMP 11: Fractional horizontal diffuse irradiance. 1/16 Dome. Azimuth=-5.42°	[W/m ²]
Mod1Ch10	CMP 11: Fractional horizontal diffuse irradiance. 1/8 Dome. Azimuth=-5.42°	[W/m ²]
Mod1Ch11	CMP 11: Fractional horizontal diffuse irradiance. 1/16 Dome. Azimuth=-49.23°	[W/m ²]
Mod1Ch12	CMP 11: Fractional horizontal diffuse irradiance. 1/8 Dome. Azimuth=-49.23°	[W/m ²]
Mod1Ch13	CMP 11: Fractional horizontal diffuse irradiance. 1/16 Dome. Azimuth=-95.5°	[W/m ²]
Mod1Ch14	CMP 11: Fractional horizontal diffuse irradiance. 1/8 Dome. Azimuth=-95.5°	[W/m ²]
Mod1Ch15	CMP 11: Fractional horizontal diffuse irradiance. 1/16 Dome. Azimuth=-140.5°	[W/m ²]
Mod1Ch16	CMP 11: Fractional horizontal diffuse irradiance. 1/8 Dome. Azimuth=-140.5°	[W/m ²]
Mod2Ch1	Not in use	
Mod2Ch2	CM 11: Horizontal diffuse irradiance with shadow ring: Radius=650 mm. Width=58 mm.	[W/m ²]
Mod2Ch3	CMP 11: Horizontal diffuse irradiance measured with tracker.	[W/m ²]
Mod2Ch4	Not in use	
Mod2Ch5	CHP 1: Beam normal irradiance measured with tracker. Internal instrument temperature measured with PT100 (see # 53)	[W/m ²]
Mod2Ch6	CM 11: Global irradiance	[W/m ²]
Mod2Ch7	CM 5: Total solar irradiance on 90° tilt West oriented	[W/m ²]
Mod2Ch8	CM 5: Total solar irradiance on 90° tilt North oriented	[W/m ²]
Mod2Ch9	CM 5: Total solar irradiance on 90° tilt East oriented. Artificial horizon for rejection of ground reflected irradiance.	[W/m ²]
Mod2Ch10	CM 5: Total solar irradiance on 90° tilt South oriented. Artificial horizon for rejection of ground reflected irradiance.	[W/m ²]
Mod2Ch11	CM 5: Total solar irradiance on 45° tilt South oriented.	[W/m ²]
Mod2Ch12	Not in use	
Mod2Ch13	Not in use	
Mod2Ch14	Not in use	

Mod2Ch15	Not in use	
Mod2Ch16	Not in use	
Mod3Ch1	Not in use	
Mod3Ch2	Not in use	
Mod3Ch3	Not in use	
Mod3Ch4	Not in use	
Mod3Ch5	Not in use	
Mod3Ch6	Not in use	
Mod3Ch7	Not in use	
Mod3Ch8	Not in use	
Mod3Ch9	Not in use	
Mod3Ch10	Not in use	
Mod3Ch11	Not in use	
Mod3Ch12	Not in use	
Mod3Ch13	Not in use	
Mod3Ch14	Not in use	
Mod3Ch15	Not in use	
Mod3Ch16	Not in use	
Measurements from Vaisala weather transmitter WXT520 (Module 4)		
wind_dir_min	Wind direction, minimum	[°]
wind_dir_avg	Wind direction, average	[°]
wind_dir_max	Wind direction, maximum	[°]
wind_speed_min	Wind speed, minimum	[m/s]
wind_speed_avg	Wind speed, average	[m/s]
wind_speed_max	Wind speed, maximum	[m/s]
air_temperature	Ambient air temperature	[°C]
relative_humidity	Relative humidity of ambient air	[%]
air_pressure	Ambient air pressure	[Pa]
rain_accumulation	Rain accumulation	[mm]
rain_duration	Rain duration	[s]
rain_intensity	Rain intensity	[mm/h]
hail_accumulation	Hail accumulation	[hits/cm ²]
hail_duration	Hail duration	[s]
hail_intensity	Hail intensity	[hits/cm ² /h]
Measurements from SPN 1 pyranometer (Module 4)		
sunshine	0 if solar irradiance $\leq 300 \text{ W/m}^2$ 1 if solar irradiance $> 300 \text{ W/m}^2$	[-]
sun_total	Total solar irradiance on horizontal with SPN1	[W/m ²]
sun_diffuse	Diffuse solar irradiance on horizontal with SPN1	[W/m ²]
Temperature measurements (Module 5)		
RTD0_Pyrheliometer	Pyrheliometer instrument internal temperature (see #21) Should be used for temperature compensation: Temperature [°C] ; deviation [%]: 50 40 30 20 10 0 -10 -20 ; 0.16 -0.02 -0.07 0.00 0.18 0.19 0.05 -0.48	[°C]
RTD1	Not in use	
RTD2	Not in use	
RTD3_Cabinet	Temperature in the cabinet of the measurement	[°C]

	equipment	
Measurements/information from sun tracker SOLYS 2 and sun sensor		
Azimuth_adjust	Azimuth adjust of tracker by sun sensor	[°]
Zenith_adjust	Zenith adjust of tracker by sun sensor	[°]
Azimuth	Azimuth angle of the tracker/sun	[°]
Zenith	Zenith angle of the tracker/sun	[°]
Function	Function	
Q1_Sun_intensity	Direct normal solar irradiance on sun sensor, above_left	[W/m ²]
Q2_Sun_intensity	Direct normal solar irradiance on sun sensor, below_left	[W/m ²]
Q3_Sun_intensity	Direct normal solar irradiance on sun sensor, above_right	[W/m ²]
Q4_Sun_intensity	Direct normal solar irradiance on sun sensor, below_right	[W/m ²]
Total_Sun_intensity	Direct normal solar irradiance on sun sensor: Q1+Q2+Q3+Q4	[W/m ²]
Solys_instrument_status		[-]
Solys_gps_time	GPS time from tracker: year, day, hour, minute, second, milisecond	[yyyy ddd hh mm ss ms]

5. References

- [1] Hans Lund, 1994. Solmålestationen. Rapport nr. 94-18. Juni 1994. Laboratoriet for Varmeisolering. Danmarks Tekninske Universitet.
- [2] Elsa Andersen^a, Kristian Pagh Nielsen^b, Janne Dragsted^a, Simon Furbo^a. Measurements of the angular distribution of diffuse irradiance. ^aTechnical University of Denmark, Institute of Civil Engineering, Nordvej 119, 2800, Kgs. Lyngby, Denmark. ^bDanish Meterological Institute, Lyngbyvej 100, 2100 Copenhagen Ø, Denmark. In proceedings of International Conference on Solar Heating and Cooling for Buildings and Industry, SHC 2014.

DTU Civil Engineering
Department of Civil Engineering
Technical University of Denmark

Brovej, Building 118
2800 Kgs. Lyngby
Telephone 45 25 17 00

www.byg.dtu.dk

ISBN 1601-8605